



YUMI DEADLY CENTRE
School of Curriculum
Enquiries: +61 7 3138 0035
Email: ydc@qut.edu.au
<http://ydc.qut.edu.au>

Numeracy for Transition to Work Year 11 Prevocational Mathematics Booklet 11.3: "Rating our World" Rate, area and volume activities and problems

The image shows the front cover of a booklet. At the top left is the Bundamba State Secondary College logo, and at the top right is the QUT logo. Below these logos, the text reads: 'Bundamba State Secondary College', 'Queensland University of Technology', and 'DEADLY MATHS CONSORTIUM'. In the center, it says 'TEACHER RESOURCE BOOKS', 'NUMERACY FOR TRANSITION TO WORK', and 'YEAR 11: SEMESTER 1'. A large, faint '11.3' is visible in the background. A white box in the center contains the text: 'PREVOCATIONAL MATHEMATICS', 'Booklet 11.3: "Rating our World"', and 'VERSION 1, 2008'. Below this box, the authors are listed: 'Bevan Penrose', 'Bundamba State Secondary College', 'Tom J Cooper', 'Annette R Baturu', 'with', 'Kaitlin Moore', 'Elizabeth Duus', 'Deadly Maths Consortium', and 'Faculty of Education, QUT'. At the bottom, a small line of text states: 'Funded by ARC Linkage Grant – Numeracy for Access to Traineeships, Apprenticeships and Vocational Studies and Empowerment and Low Achieving Post Year 10 Students'.

YuMi Deadly Maths
Past Project Resource

Acknowledgement

We acknowledge the traditional owners and custodians of the lands in which the mathematics ideas for this resource were developed, refined and presented in professional development sessions.

YuMi Deadly Centre

The YuMi Deadly Centre is a Research Centre within the Faculty of Education at Queensland University of Technology which aims to improve the mathematics learning, employment and life chances of Aboriginal and Torres Strait Islander and low socio-economic status students at early childhood, primary and secondary levels, in vocational education and training courses, and through a focus on community within schools and neighbourhoods. It grew out of a group that, at the time of this booklet, was called “Deadly Maths”.

“YuMi” is a Torres Strait Islander word meaning “you and me” but is used here with permission from the Torres Strait Islanders’ Regional Education Council to mean working together as a community for the betterment of education for all. “Deadly” is an Aboriginal word used widely across Australia to mean smart in terms of being the best one can be in learning and life.

YuMi Deadly Centre’s motif was developed by Blacklines to depict learning, empowerment, and growth within country/community. The three key elements are the individual (represented by the inner seed), the community (represented by the leaf), and the journey/pathway of learning (represented by the curved line which winds around and up through the leaf). As such, the motif illustrates the YuMi Deadly Centre’s vision: *Growing community through education*.

More information about the YuMi Deadly Centre can be found at <http://ydc.qut.edu.au> and staff can be contacted at ydc@qut.edu.au.

Restricted waiver of copyright

This work is subject to a restricted waiver of copyright to allow copies to be made for educational purposes only, subject to the following conditions:

1. All copies shall be made without alteration or abridgement and must retain acknowledgement of the copyright.
2. The work must not be copied for the purposes of sale or hire or otherwise be used to derive revenue.
3. The restricted waiver of copyright is not transferable and may be withdrawn if any of these conditions are breached.

© QUT YuMi Deadly Centre 2009
Electronic edition 2013

School of Curriculum
QUT Faculty of Education
S Block, Room S404, Victoria Park Road
Kelvin Grove Qld 4059
Phone: +61 7 3138 0035
Fax: + 61 7 3138 3985
Email: ydc@qut.edu.au
Website: <http://ydc.qut.edu.au>

CRICOS No. 00213J

This booklet was developed as part of a project which ran from 2005–2008 and was funded by an Australian Research Council Linkage grant: LP0455667 *Numeracy for access to traineeships, apprenticeships, and vocational studies and empowerment and post Year 10 students*.

Bundamba State Secondary College &
Queensland University of Technology

TEACHER RESOURCE BOOKLETS
NUMERACY FOR TRANSITION TO WORK

YEAR 11 PREVOCATIONAL MATHEMATICS
BOOKLET 11.3: "RATING OUR WORLD"
VERSION 1: 2009

Research Team:
Bevan Penrose
Tom J Cooper
Annette R Baturo
with
Kaitlin Moore
Elizabeth Duus

Deadly Maths VET
School of Mathematics, Science and Technology Education,
Faculty of Education, QUT

DEADLY MATHEMATICS VET

Deadly Maths VET was the name given to the materials produced to support the teaching of numeracy to vocational education and training students, particularly those from Indigenous backgrounds. These booklets were produced by the *Deadly Maths Consortium* at Queensland University of Technology (QUT) but also involving a researcher from Nathan Campus of Griffith University.

At the time of the production of this booklet, Deadly Maths VET was producing materials as part of an ARC-funded Linkage grant LP0455667 (12 booklets on Years 11 and 12 Prevocational Mathematics course and 2 booklets on pesticide training) and ASISTM-funded 2008 grant (3 booklets on construction; 3 booklets on engineering; 3 booklets on marine; 1 booklet on retail; and 2 booklets and a series of virtual materials on basic mathematics).

CONTENTS

| | Page |
|---|-------------|
| THE PREVOCATIONAL MATHEMATICS BOOKLETS | iv |
| OVERVIEW..... | 1 |
| 1. Theoretical position | 1 |
| 2. Mathematics for this booklet | 1 |
| 3. Pedagogy | 2 |
| 4. How to use this booklet | 3 |
| PRELIMINARY ACTIVITIES..... | 4 |
| 1. Rate vs ratio | 4 |
| 1.1. Attributes and number types | 4 |
| 1.2. Rate vs ratio activities..... | 4 |
| 2. Area and volume | 5 |
| 2.1. Area | 5 |
| 2.2. Volume | 6 |
| 2.3. Area and volume activities..... | 7 |
| 3. Multiplying rates..... | 8 |
| 3.1. Multiplication | 8 |
| 3.2. Double number line | 8 |
| 3.3. Multiplication change | 9 |
| 3.4. Multiplication activities | 9 |
| 4. Calculating rates in problems | 10 |
| 4.1. Calculating rate | 10 |
| 4.2. Finding starting amount..... | 11 |
| 4.3. Calculating rates in problems activities | 11 |
| 5. Multi-step problems..... | 12 |
| CULMINATING TASK..... | 13 |
| ASSESSMENT RUBRIC | 15 |

THE PREVOCATIONAL MATHEMATICS BOOKLETS

In 2005 to 2008 researchers Annette Baturo and Tom Cooper from the Deadly Maths Consortium received an ARC Linkage grant (LP0455667) to study mathematics learning of Year 11 and 12 and adult students undertaking vocational education and training (VET) courses who had low achievement in mathematics. The title of this ARC Linkage project was *Numeracy for Access to traineeships, apprenticeships, and vocational studies and empowerment and post year ten students*. The project studied better ways to teach mathematics to VET students at Bundamba State Secondary College, Metropolitan Institute of TAFE (Moreton Campus), Gold Coast Institute of TAFE (Ridgeway Campus), Tagai College (Thursday Island Campus), and the Open Learning Institute of TAFE.

As part of the study, the Deadly Maths research team developed booklets and other resources to be trialled by VET students and teachers. The project's activity with Bundamba State Secondary College focussed on the Year 11 and 12 Prevocational Mathematics subjects taught at that college to less able mathematics students. The project used a series of intervention case studies to research learning. As part of this, the following 12 Prevocational Mathematics resource booklets were produced (6 for Year 11 and 6 for Year 12). The booklets are numbered 11.1 to 11.6 and 12.1 to 12.6.

- 11.1 – “Using Numbers of Numbers” – Yr 11 prevocational maths booklet: Number, decimals, fractions and problem solving.
- 11.2 – “The Big Day Out” – Yr 11 prevocational maths booklet: Number, tables, budgeting, algebra and problem solving.
- 11.3 – “Rating our World” – Yr 11 prevocational maths booklet: Rate, area and volume activities and problems.
- 11.4 – “Exchange Student” – Yr 11 prevocational maths booklet: Operations, discounts, tables, metric conversion and best buys.
- 11.5 – “Planning a Roster” – Yr 11 prevocational maths booklet: Tables, 24-hour time, percentages and computation strategies.
- 11.6 – “The Man from Hungary” – Yr 11 prevocational maths booklet: Time relationships, time calculations, timetables and efficient scheduling.
- 12.1 – “Beating the Drought” – Yr 12 prevocational maths booklet: Fractions, probability, graphing and data.
- 12.2 – “Monopoly” – Yr 12 prevocational maths booklet: Fractions, probability, game strategies, property finance, graphs and tables.
- 12.3 – “How tall is the Criminal?” – Yr 12 prevocational maths booklet: Multiplicative structure, ratio and proportion, problem solving.
- 12.4 – “Design a Kitchen” – Yr 12 prevocational maths booklet: Visual imagery, percent, rate, ratio, perimeter, area and volume.
- 12.5 – “Healthy Eating” – Yr 12 prevocational maths booklet: Data collection and analysis, tables and graphing (line and histograms).
- 12.6 – “Rocking around the World” – Yr 12 prevocational maths booklet: Time and angle, time operations and problem-solving strategies.

OVERVIEW

1. Theoretical position

The Bundamba Prevocational Mathematics booklets are based on the notion of Renzulli (1977) that mathematics ideas should be developed through three stages.

Stage 1: Motivate the students – pick an idea that will interest the students and will assist them to engage with mathematics.

Stage 2: Provide prerequisite skills – list and then teach all necessary mathematics ideas that need to be used to undertake the motivating idea.

Stage 3: Culminating task – end the teaching sequence by setting students an open-ended investigation to explore.

These booklets use Stage 3 as an assessment item and so we have added an assessment rubric whereby the culminating task can be used to check the knowledge held by the student.

The booklets combine two approaches to teaching:

- (1) structural activities that lead to the discovery and abstraction of mathematical concepts, processes, strategies and procedures; and
- (2) rich-style tasks which allow students an opportunity to solve problems and build their own personal solution.

2. Mathematics for this booklet

This booklet focuses on how to use **rate** to determine measure. Rate and ratio are different in three ways:

- (1) Ratio compares the same attributes (for example, sand and cement in mass are 5:2 – that is 5 tonnes of sand is used with 2 tonnes of cement); rate compares different attributes (for example, the cost of petrol is \$1.20 per litre which compares money to volume).
- (2) Ratio uses rotation similar to fractions in that there are two whole numbers (but part to part, not part to whole – for example, sand to cement is 5:2; rate uses a single number, for example, \$1.20 per litre). Rate could really be considered as a ratio with 1 as the second number (for example, \$ to litres is \$1.20:1 litre); it uses the single number and is like a fraction.
- (3) Ratio problems are worked out by using proportion or equivalent ratio (for example, if sand to cement is 5:2 and we wish to make 8 tonnes of cement, then we need 20 tonnes of sand as 20:8 is the same as 5:2); rate problems use multiplication (for example, if petrol is \$1.20 per litre then 4 litres is $\$1.20 \times 4 = \4.80).

Rate problems are best understood in three ways:

- (1) Concept: Multiplication can be taught as rate by number (for example, 3 bags of lollies/bag \times 4 bags = 12 lollies). Note that the attribute for the number is the same as the second attribute for the rate and the answer is the first attribute of the rate.

- (2) Double number line: The top of the line is one attribute while the bottom of the line is the other.

So \$1.20/litre and 4 litres is:
 Answer is $\$1.20 \times 4 = \4.80

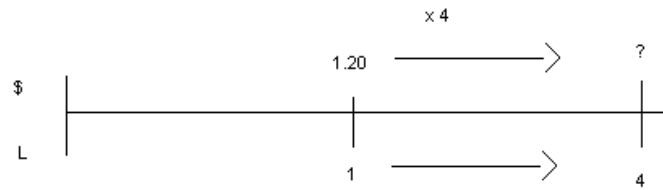

This works both ways:
 e.g. \$1.20/litre and I have \$6.00:
 Answer is 5 litres

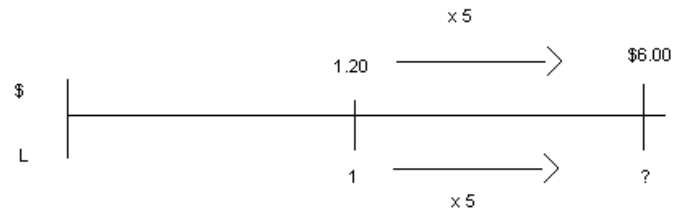

- (3) Multiplier (multiplication change diagram)

Rate can be considered as a multiplication change from second to first attribute, for example, 4L changes to \$6 by change \$1.20/litre.

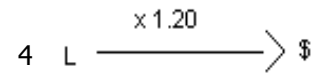

(a) 4 L is: ? $4 \text{ L} \xrightarrow{\times 1.20} \$?$
 $? = 4 \times \$1.20 = \4.80

(b) \$6 is: ?L $? \text{ L} \xrightarrow{\times 1.20} \6.00
 $? = 6 / 1.20 = 5\text{L}$

(c) Rate is: $4\text{L} \xrightarrow{\times ?} \6.00
 $? = \$6/4\text{L} = \1.20 per litre

Note: End unknown is multiplication while start unknown and change of multiplier unknown is division.

There are three problem types:

- (1) Given a rate find the first attribute for a second attribute (for example, \$2/L and 7L costs \$14 (×)).
- (2) Given a rate find the second attribute for the first (for example, \$2/L and \$10 gives 5L (÷)).
- (3) Given both attributes, calculate rate (for example \$12 for 4L is \$3/L).

Rates are calculated by ensuring that the second attribute is 1. So, \$8 for 2L is $8 \div 2$ or \$4/L. Similarly, 34 tonnes in 5 hours is 6.8 tonnes/hour.

3. Pedagogy

The pedagogy for the culminating task is to (a) interest the students in the situations so they are engaged in the task, (b) provide them with all they need mathematically to gather information and computer totals, and (c) let them develop their solution as they see fit.

The pedagogy for the prerequisite skills is to develop mental models (pictures in the mind) and connect all representations for the mathematics concepts, processes, strategies and procedures that are needed to tackle the culminating task.

- (1) language, for example, cost per cent, greater, smaller, and so on; and
- (2) symbols, for example, $300\text{g} \div 68\text{c} = 4.41 \text{ g/c}$.

Thus instruction is based on the so-called Rathmell Triangle (Payne & Rathmell, 1978):

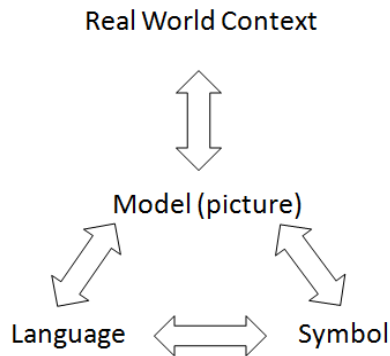

The prerequisite pedagogy also involves three major generic strategies:

- (1) Flexibility – trying to ensure students understand things in a variety of ways (e.g. discount, reduction, etc.; %, part per 100, decimal hundredths, fraction out of 100, and so on).
- (1) Reversing – trying to teach in all directions (e.g. real-world situation to best buy; best buy to real-world situation).
- (2) Generalising – trying to teach things in the most general way (going beyond the needs of a task).

Particular strategies for tackling some of the preliminary activities will be provided at the start of the activities.

4. How to use this booklet

The major focus of the unit is the culminating task. The preliminary activities are only suggestions for prior work if you think your students require this work before they begin the culminating task. Therefore:

- (1) use the culminating task as the focus of the unit – to motivate engagement;
- (2) look through the preliminary activities and pick and choose things that you believe will be useful for your students – it is not necessary to do everything and to do it in the order that it appears in this booklet (although there is a logic to the order);
- (3) do these activities as a lead in to the culminating activity; and
- (4) try to organise things so that the students can do the culminating activity as an assessment of their abilities to do mathematics.

The preliminary activities are in five sections and there are real activities at the end of each section. The earlier parts of each section simply explain the ideas/models/pictures in the mind that are being attempted. Although how they are presented gives some hints on pedagogy, you will have to determine your own way to teach these.

PRELIMINARY ACTIVITIES

1. Rate vs ratio

The culminating task for this booklet focuses on rate. We begin by looking at the nature of rate (particularly in relation to ratio).

1.1. Attributes and number types

Rate and ratio are names for comparison by multiplication, that is, comparing 24 to 6 we see that 24 is 4 times larger than 6. Rate and ratio have different histories and so instead of one way of viewing multiplicative comparison, we have two. Ratio is used when attributes are the same, that is, 7L of water to 2L of cordial gives a ratio of 7:2. Rate is used when there are different measures, that is, \$7 is the cost of 2L of cordial gives a rate of $\$7/2L = \3.50 per 1L. Thus, there are two differences:

- (1) In the diagram on right, ratio is the shaded areas and rate is the unshaded.
- (2) Rate has one number and ratio has two, for example, foot length to height is 1:6 (ratio) and cloth costs \$8 per metre (rate).

| | \$ | Length | Area | Volume | Mass | Time |
|--------|----|--------|------|--------|------|------|
| \$ | | | | | | |
| Length | | | | | | |
| Area | | | | | | |
| Volume | | | | | | |
| Mass | | | | | | |
| Time | | | | | | |

1.2. Rate vs ratio activities

- (1) Mark the following as rate or ratio:
 - (i) Sand and cement is mixed mass to mass
 - (ii) Sand costs dollars per mass
 - (iii) Paint covers area per volume
 - (iv) Cordial is mixed with water volume to volume
- (2) State a rate for where there is:
 - (i) Area and length
 - (ii) Time and money
 - (iii) Mass and volume
- (3) Mark the following as rate or ratio:
 - (i) Butter to milk is 1:2
 - (ii) Butter costs \$5.40 per kilogram
 - (iii) The pressure is 2kg per square cm
 - (iv) Number of bottles of coke to bottles of lemonade is 4:3
- (4) Make up a rate or ratio problem for:
 - (i) 6.4
 - (ii) 4.7

2. Area and volume

Some rate problems involve two steps, for example, *At what rate does water flow off a roof 3m by 5m if the rain is 4mm/hour?* This requires working out the volume ($300 \times 500 \times 0.4 \text{ cm}^3$) and dividing this by 1000 to give litres. Area and volume are common components of two-step rate problems (and are part of the Culminating Task); therefore, we shall spend some time on them.

2.1. Area

The best model of area (and one which relates area to multiplication) is the array. For example:

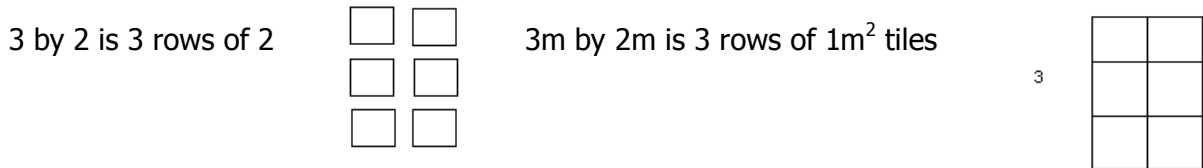

The relationship between area and multiplication can be discovered for squares and rectangles, by counting squares and filling in a table like that which follows the grid:

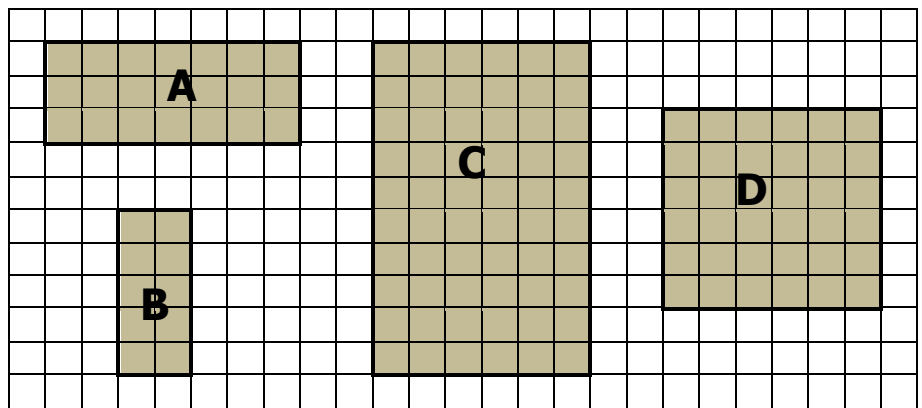

| Rectangle | Length (L) | Width (W) | Area (A) |
|-----------|------------|-----------|----------|
| A | | | |
| B | | | |
| C | | | |
| D | | | |

The question to ask is “What is the area of rectangle in terms of length and width?” (Area = Length \times Width).

Areas of different shapes can then be found by relating them to the area of a rectangle. For example, take a rectangle, cut out a triangle, put the two pieces together and form two triangles. This relationship can be reinforced by taking two triangles, cutting one as shown and forming a rectangle.

The questions are (a) “What is the relationship between triangle and rectangle?” and (b) “What is area of triangle in terms of length and width?”.

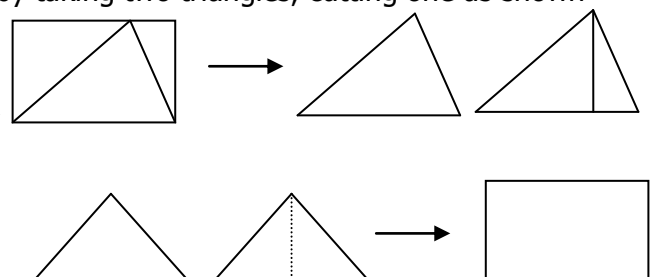

2.2. Volume

Volume can be developed from area by looking at area as the base and then building height. For example, see the following steps:

- (1) What is the area of this shape?

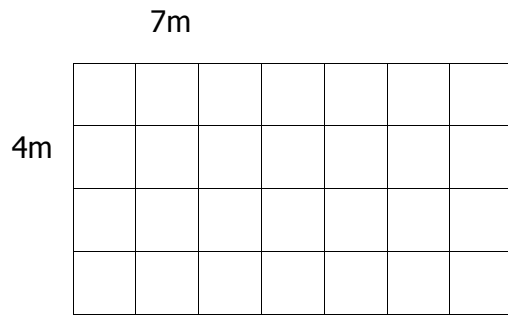

- (2) Make it out of cubes – ask “What is the volume?”. “How does it relate to the area of the base?”.

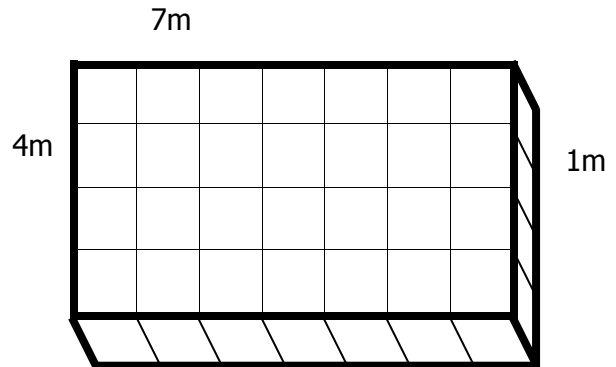

- (3) Add another layer – ask “What is the volume?”. “How does it relate to the area of the base?”

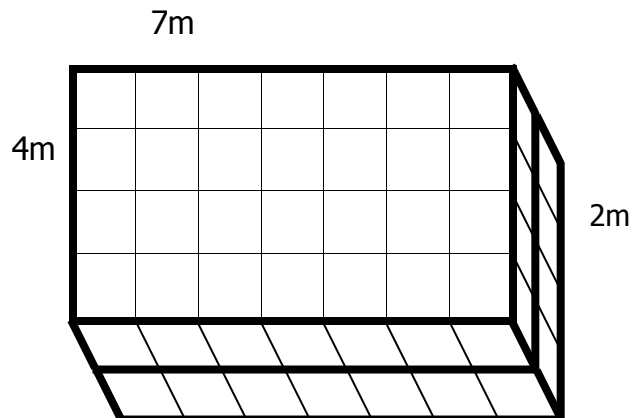

- (4) And a third – ask the same questions.

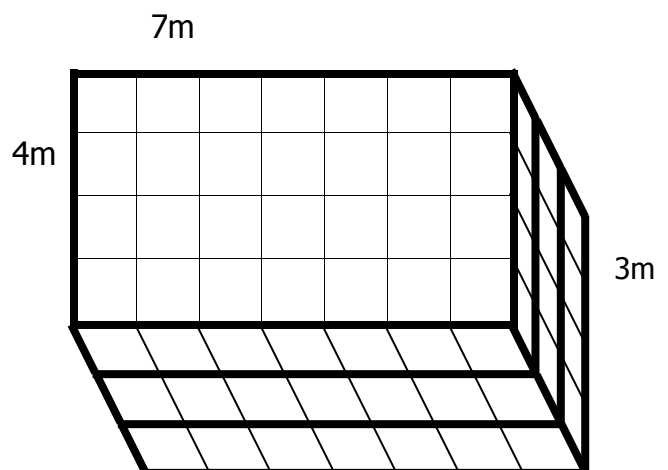

- (5) Ask the overall question: “What is the relationship between volume, area of base and number of layers?”

Then, this general relationship between area of base and volume can be used in examples like:

What is the volume of the following?

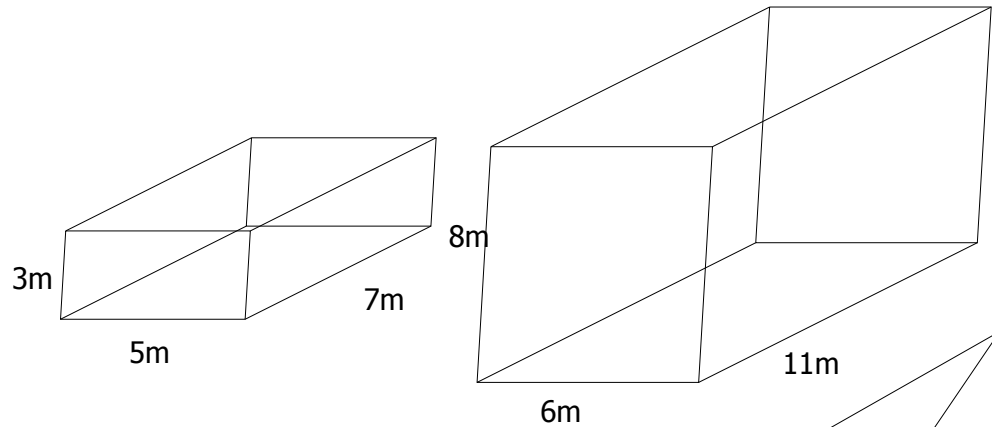

Repeat this for triangles: What is the volume of the following?

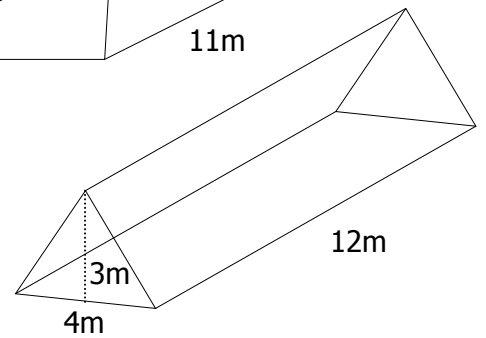

Repeat this for a combination of triangles, squares, and rectangles:

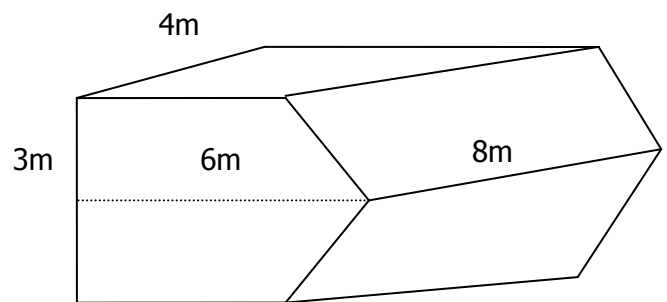

2.3. Area and volume activities

(1) Calculate the area (use a calculator) of the following:

(a) 7m by 13m rectangle

(b)

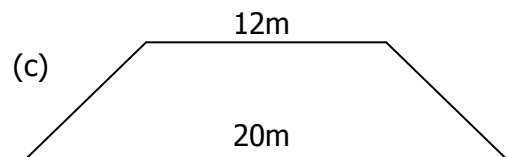
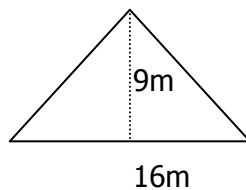

(2) Calculate the volume for the following:

(a) 3m by 4m by 5m rectangular prism

(b) Rectangular prism figured right:

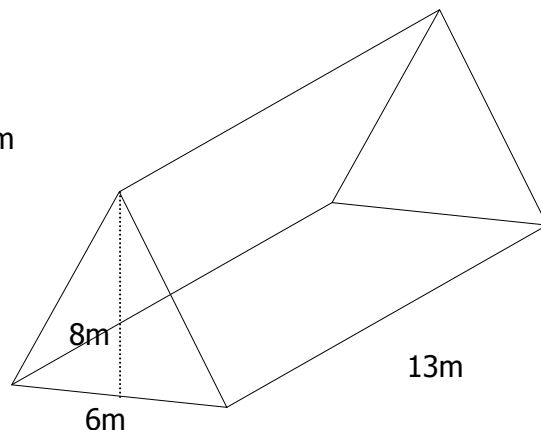

(c) Figure at right:

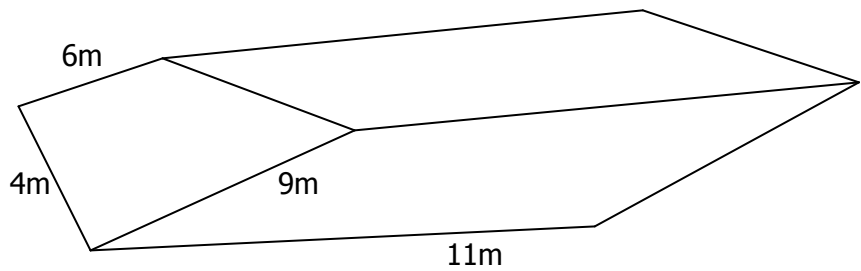

3. Multiplying rates

Rates can be directly multiplied by considering multiplication as rate by measure (for example, 4 lollies/bag \times 7 bags = 28 lollies) or through double number lines and multiplication diagrams.

3.1. Multiplication

(1) Three bags of lollies with 4 lollies in each bag

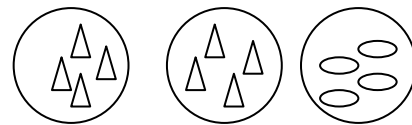

(a) Draw a representation:

(b) Multiply the number in each group by the number of groups

(2) $3 \times 4 = 12$

(a) Look at this in terms of rate

(b) 4 lollies/bag \times 3 bags = 12 lollies

(3) Repeat this for other examples

(a) 3 trees per row \times 5 rows = 15 trees

(b) 5 blocks per runner \times 6 runners = 30 blocks

(4) The pattern is:

(a) Numbers are multiplied

(b) Attributes are "cancelled" (for example, lollies \div bag \times bag = lollies)

3.2. Double number line

(1) Use the rate to develop the double number line – to name the top and bottom of the line.

For example: The cost of mobile phone calls was 46 cents per minute.

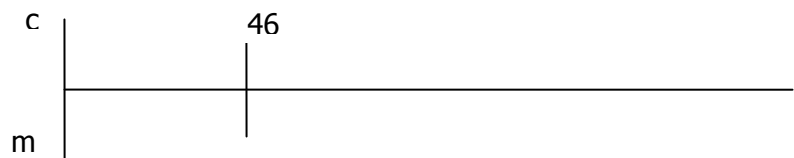

(2) Use the other value to develop a multiplier.

For example: How much for a 7.5 minute call?

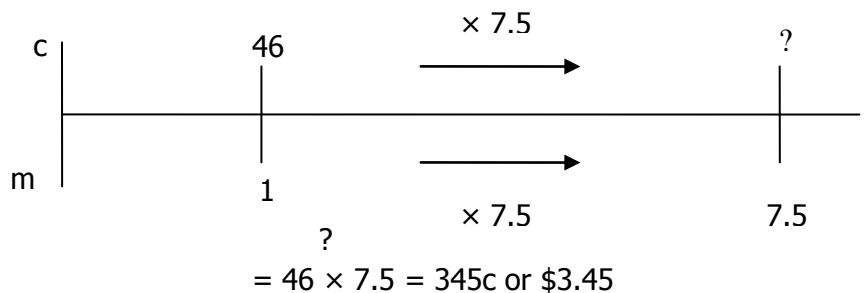

- (3) Once the double number line is identified, the multiplication of rates is straightforward.
 For example: The heater uses 0.75 kW/hour. If the heater is left on for 8.25 hours, how many kilowatts are used?

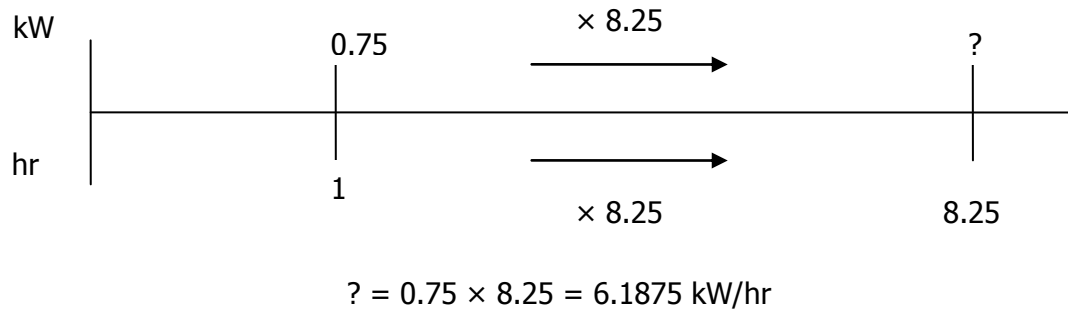

3.3. Multiplication change

A rate can be seen as a multiplication change from the second to the first attribute.

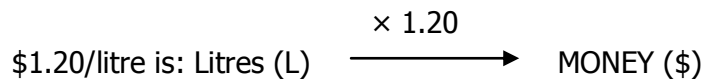

Hence a problem can be placed on this multiplication diagram. For example: Petrol is \$1.20/L. How much for 6.5 L?

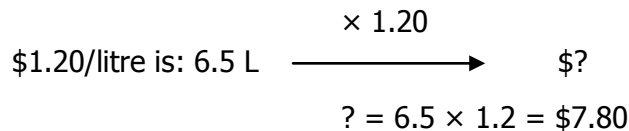

3.4. Multiplication activities

- (1) Identify which of these are rate multiplication:
 - (a) 4 apples/box \times 7 boxes
 - (b) 6 pencils/box \times 3 rulers
 - (c) 5 carriages/train \times 6 carriages
 - (d) 8 trucks \times 6 cars/truck
- (2) Calculate the following (use your calculator)
 - (a) Rain fell at 7.5mm per hour. How much did the swimming pool fill in 4.5 hours?
 - (b) The painter used 0.7L of paint for 1m². How many litres of paint are needed to cover 7.48m²?
- (3) Draw the double number lines for the following:
 - (a) Cost of liquorice is 2.5c/cm
 - (b) Computer downloads are 17c/min
- (4) Use a double number line to solve the following:
 - (a) Paint is \$12 per litre. How much for 25 litres?
 - (b) Smarties were \$17.60/kg. How much for 1.35 kg of smarties?

- (5) Draw a multiplication diagram for the following:
 - (a) Cost of wood is \$5.60/metre
 - (b) Cost of phone calls is 46c/min
- (6) Use a multiplication diagram for the following:
 - (a) Cleaning is \$16/hour. How much does it cost for 7.25 hours of cleaning?
 - (b) The water pump delivers 235L/hours. How many litres for 15 hours of pumping?

4. Calculating rates in problems

There are three types of rate problems:

- (1) Given rate and starting amount, find end value.
 For example: \$1.20/L; 6L → ?\$; $? = 1.20 \times 6 = \$7.20$
- (2) Given rate and ending amount, find starting amount.
 For example: \$1.20/L; ?L → 6\$; $? = 6 \div 1.2 = 5L$
- (3) Given starting and ending amount, find the rate.
 For example: \$?/L; 5L → \$6; $? = 6 \div 5L = 1.20/L$

4.1. Calculating rate

When a relationship between two amounts is given there is often a need to calculate the rate. For example: The car travelled 1.95km in 3 hours. What was the speed? To do this we need to divide the numbers. This can be seen using two methods. Steps are as follows.

(1) Double number line

Determine in the rate which one is the "per". For example, for \$/L the "per" is litres. For km/hr, the "per" is hours. This is the bottom of the line and the attribute is the top of the line.

For example: the car travelled 195km in 3 hours. What was the speed? Speed is km/hr so hour on the bottom and km on the top.

The hour is the 1 (one). So drawing is as follows:
 So, $? = 195 \div 3 = 65 \text{ km/hr}$

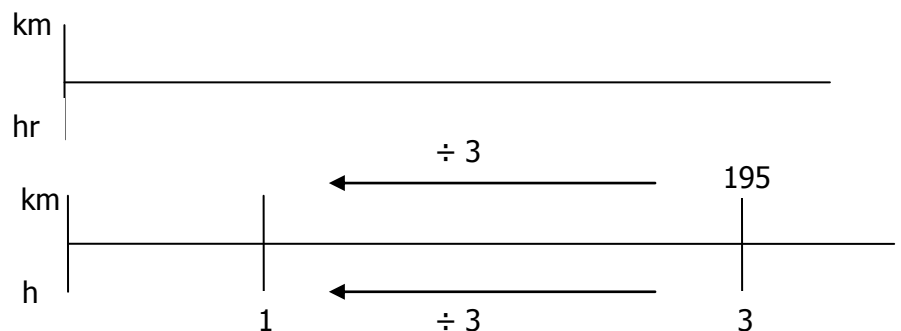

(2) Multiplication change diagram

Look again at speed as km/hr. Thus, this rate is a change model. $\times \text{Rate}$
 hr → km

For example: The car travelled 195km in 3 hours. What was the speed? The diagram is:

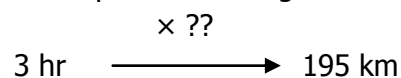

To find the rate, divide 195 by 3.

4.2. Finding starting amount

It is easy, if given a rate of \$1.20/L and a second attribute which is 5L, to calculate the money ($= 5 \times 1.2 = \$6$). It is more difficult to reverse this. To do this, let us look at two examples:

- (a) The pay is \$15/hour, how many hours for \$45?
- (b) The water flows at 65L/hr, how long for 350L?

(1) Double number line

The numbers are placed on double number line and the "division" change identified:

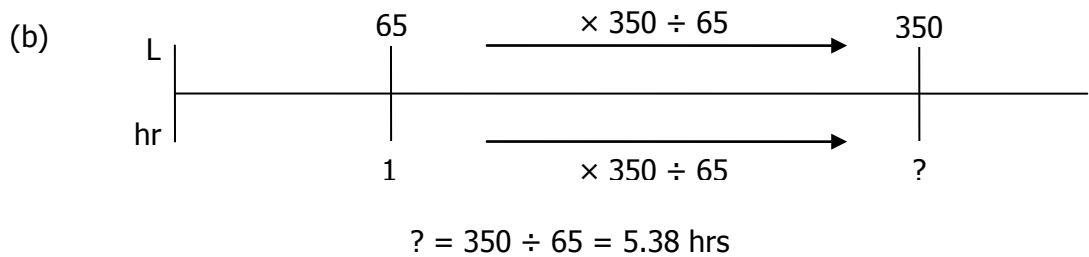
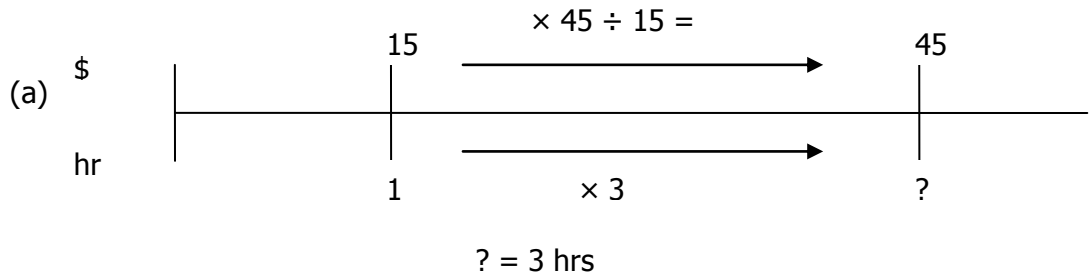

(2) Multiplication change diagram

The unknown is at the left of the diagram requiring division for the answer:

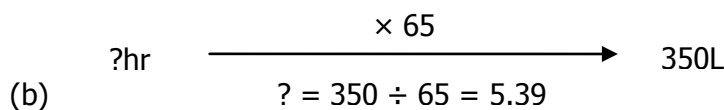
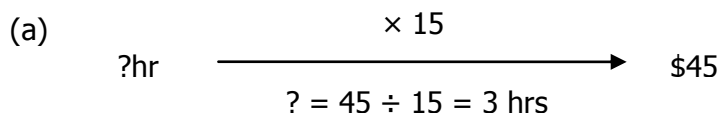

4.3. Calculating rates in problems activities

- (1) Use double number lines to solve the following:
 - (a) The cost of mobile phone calls was 75c per 30 seconds. What was the rate in terms of cents/sec?
 - (b) The petrol cost for 45L was \$57.30. What was the rate in terms of \$/L?
- (2) Use multiplication change diagram to solve the following:
 - (a) The tap delivered 47L of water in 5 hrs. What is the rate in terms of L/hr?
 - (b) The painter covered 20m^2 of wall with 8L of paint. What is the painting rate in terms of m^2/L ?

5. Multi-step problems

Many rate problems involve more than one step. For example, a rate may need to be calculated before it can be used to find answers, or a rate may be in terms of something (e.g. area) which has to be calculated from other measures like length.

The answer here is to focus on the rate and to break the problem into steps and do each step one after the other.

- (1) The car used 40L of petrol to travel 350km. How much petrol would it need to travel 500km?

Step 1: What is the rate to be used? (L/km)

Step 2: Break into parts: (a) Petrol L/km; (b) Use L/km

Step 3: Do each part using a calculator: (a) 40L for 350km means rate is $40 \div 350$ L/km; (b) 500km means that use = $40 \div 350 \times 500$ L = 57.14L

Notes: We could have made rate km/L and used the multiplication change diagram.

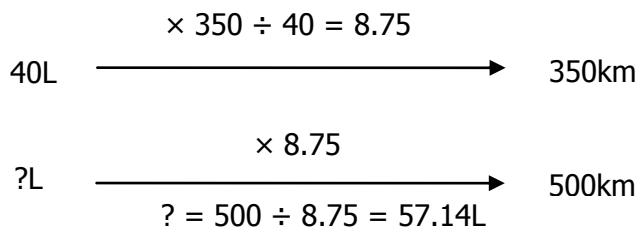

- (2) We can use double number line in one step (it does not matter if is km/L or L/km).

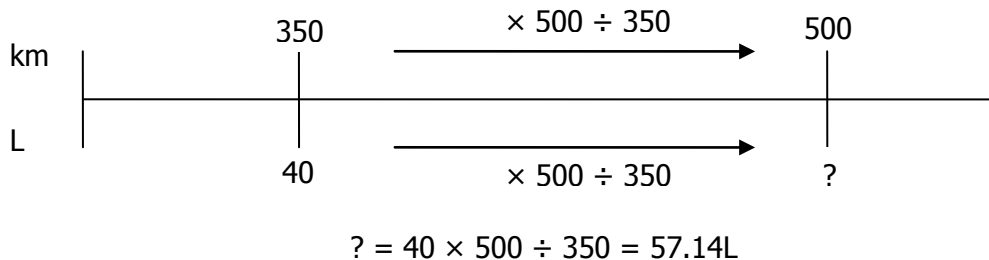

- (3) The hose is delivering 50L/min. How long to fill a $3\text{m} \times 1.5\text{m} \times 2\text{m}$ tank?

Step 1: What is the rate to be used? (50L/min)

Step 2: Break into parts: (a) find volume in litres, (b) use rate to find time

Step 3: Do each part using a calculator:

Volume = $300 \times 150 \times 200 \text{ cm}^3$ or mL = $(300 \times 150 \times 200) \div 1000 \text{ L} = 9000\text{L}$

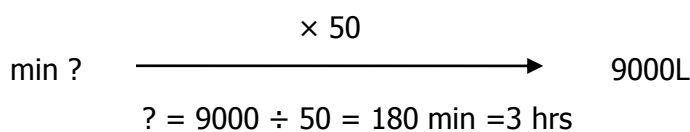

CULMINATING TASK

RATING OUR WORLD

Directions: This third assignment in the course requires you, the student, to engage with different types of ratios and rates in problems involving the costs associated with the home. All work is to be done on your own paper and attached to this assignment sheet.

A *ratio* is a comparison of two numbers of the same type. A *rate* is a comparison of quantities of a different kind.

With energy use in the news, it is an opportune time to investigate the cost of electricity in our homes. Power is the *rate* at which energy is used.

On every electrical appliance there is a power rating. For example, the power rating for the laptop computers that teachers use is 65 Watts. If the laptop was used for 4 hours, the energy use is $65 \text{ Watts} \times 4 \text{ hours} = 260 \text{ Watt hours} = 0.260 \text{ kilowatt hours (kWh)}$. The unit of energy used to charge household use is the kilowatt hours (kWh).

You will need to go on the Internet and find the tariff for your area from your local energy company.

Task One:

Using the table headings below as a guide, make a list of all the electrical appliances in your home. For each appliance record the power rating. Estimate the number of hours each appliance is used in your home each week. Use this information to calculate the total energy consumed by electrical appliances in your home each week.

Table Headings (Guide only):

| Appliance | Power Rating (W) | Hours/week | Energy used (kWh) |
|-----------|------------------|------------|-------------------|
| Jug | 1500 | 2.5 | 3.75 |
| | | | |
| | | | |

Hint: You may find it easier to list all the appliances by placing them into categories.

Heating and cooling devices: Air conditioner reverse cycle, 3 bar heater etc.

Cooking: Microwave, fan-forced oven, etc.

General household use: Refrigerator, water heater, pool pump etc.

Entertainment: Radio, DVD, computer, etc.

Task Two:

Use the information from question one to calculate the quarterly cost of electricity for your household. Compare this with your usual household quarterly bill. What are the likely reasons for any differences in the amounts? List ways your family could reduce electricity use. Calculate the reduced energy use as a percentage of original total energy use.

Task Three:

South East Queensland is suffering from a lack of rain. This has caused the government to implement level 5 water restrictions. We are being urged to use less water. In the coming

years, we will certainly have to pay more for our water. The table below gives the amount of water used for a typical household. All values are approximate.

Source <http://www.melbourne.vic.gov.au/rsrc/PDFs/Water/CalculatorWaterMark.pdf>

| Water Use | Volume (L) |
|--|---------------------|
| Dual flush toilet Single flush | 5 |
| Dual flush toilet Double flush | 11 |
| Shower (7.5 L/minute) for low water flow shower head | 30 per 4 min shower |
| Shower (12 L/minute) regular shower head | 48 per 4 min shower |
| Bath | 96 |
| Washing water efficient AAAA front loading per load | 40 |
| Regular washing machine per load | 130 |
| Meal preparation | 5 |
| Washing up | 10 |
| Jug | 2 |
| Dishwasher | 40 |
| Bucket for garden watering | 9 |
| Swimming pool top up for 50000L pool | 720 |
| Teeth cleaning with tap running | 5 |
| Teeth cleaning with set amount | 1 |
| <i>Other water uses</i> | |

Use the table above to calculate the volume of water used in your household every week. Remember to take account of all the people who live in the house in a typical week.

Task Four:

At present, the cost of water is \$2.00 per kilolitre. How much would you expect your household to pay for a quarter? List ways your household could save water. Calculate the reduced amount of water as a percentage of your current use.

Many people are installing rainwater tanks. How much rain can we collect in Ipswich in a typical year? For example,; If 5 mm of rain fell on an area 100 cm × 100 cm what volume of rain has fallen?

$$\begin{aligned} \text{Volume} &= 0.005 \text{ m} \times 1 \text{ m} \times 1 \text{ m} = 0.005 \text{ m}^3 = 0.005 \text{ m}^3 \times 1000 \text{ L/m}^3 \\ &= 5\text{L} \end{aligned}$$

The average rainfall in Ipswich per year is 863.1 mm

Task Five:

Use a suitable method to calculate the area of your roof. Your answer should include a diagram. Use this answer and the information above to calculate the average volume of water which could be collected in Ipswich in a year.

Task Six:

What percentage of your typical household use (Answer to question three) could be accommodated by a rainwater tank? If the Ipswich average rainfall fell to 60% of its current level what percentage of your household use could be accommodated by a rainwater tank?

Construct a table to show the percentage of household water a tank would hold if the average Ipswich rainfall is 10%, 20%, 30%, 40%, 50%, 60%, 70%, 80%, 90% and 100% of the current average.

ASSESSMENT RUBRIC

Assessment Form

| Question | Knowledge | Application | Explaining |
|--------------------------------|-----------|-------------|------------|
| Q1 Table of energy use | | | |
| Q2 Reducing energy use | | | |
| Q3 Water use | | | |
| Q4 Reducing water use | | | |
| Q5 Roof size and Ipswich water | | | |
| Q6 Table | | | |
| Overall Grade | | | |

Assessment Criteria

| Grade | Knowledge | Application | Explaining |
|-------|--|---|--|
| A | Effectively uses given rules to carry out tasks. | Applies rules across all contexts effectively. | Presents detailed solutions logically and clearly. |
| B | Uses given rules to carry out tasks. | Applies rules across most contexts effectively. | Presents solutions logically and clearly. |
| C | Uses given rules adequately to carry out tasks. | Applies rules adequately across most contexts. | Presents readable solutions. |
| D | Uses given rules to carry out parts of tasks. | Applies rules in some contexts adequately. | Presents partial solutions. |
| E | Did not meet standard D. | Did not meet standard D. | Did not meet standard D. |